

## SPOOL INSULATOR

(ANSI Standard Type)

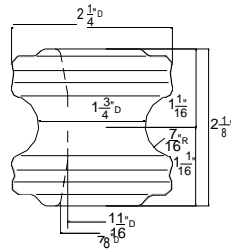

Fig 1

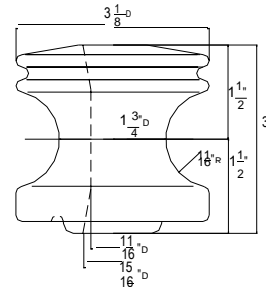

Fig 2

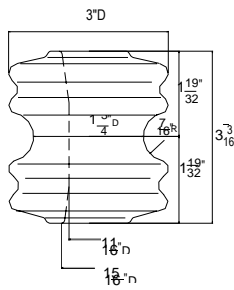

Fig 3

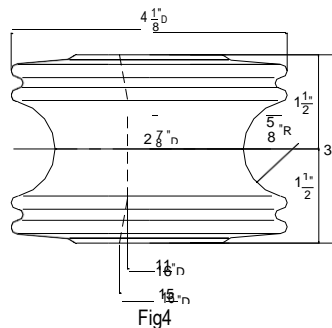

Fig 4

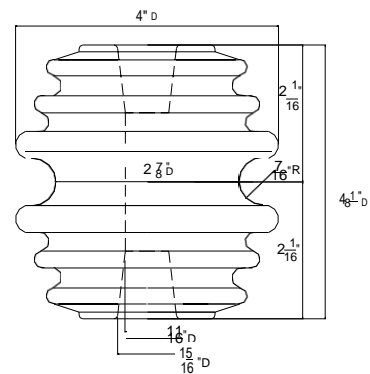

Fig 5

## STANDARD PARTICULARS

Fig No.	1	2	3	4	5
ANSI Class	53-1	53-2	53-3	53-4	53-5
Transverse Strength/lb(KN)	2000(89)	3000(13.3)	4000(17.8)	4500(20)	6000(26.7)
Average	Low-Freq. Dry/KV				
Flashover	Low-Freq. Vertical				
Voltage	Wet/KV Horizontal				
Net Weight /lb(kg)	0.48(0.22)	1.2(0.55)	1.2(0.55)	2.2(1.0)	2.6(1.2)

Notes: 1. In mechanical test, glaze chips or partial porcelain cracks should be allowed.

2. Hardware for these insulators are available upon request. Standard

Specification: ANSI C29.3

NON-STANDARD SPOOL INSULATOR

(ANSI Standard Type)

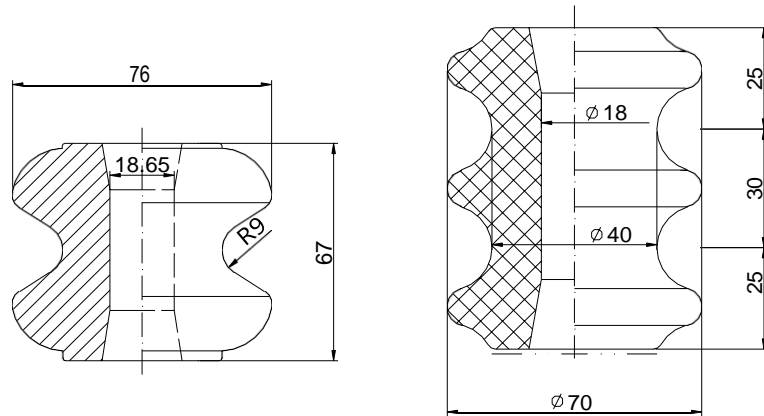

STANDARD PARTICULARS

Fig. No.		1	2
Low frequency flashover-KV		20	25
Low frequency wet flashover	Vertical-KV	10	12
	Horizontal-KV	9	15
Transverse strength –KN		9.5	13.5
Weight (approx.)-kg		0.4	0.4