

GROUNDING FITTINGS

1. Grounding Clamp

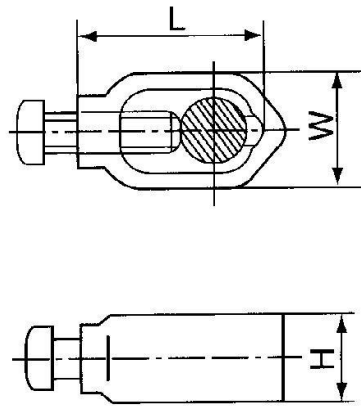

Catalog No.	Dimensions (mm)			Weight (kg)	Coating
	L	W	H		
GDX-16	50	32	25	0.85	Hot-dip galvanized
GDX-16	50	32	25	0.85	Copper plated
GDX-16	42	27	25	0.20	Brassing

The body is made of malleable iron or brassing. The bolt is hot-dip galvanized steel or brassing.

2. Grounding Rod

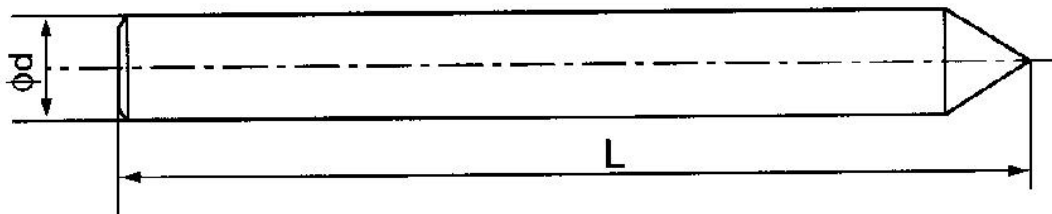

Catalog No.	Dimensions (mm)		Weight (kg)	Coating
	d	L		
JDX-1410	14	1000	1.2	Hot-dip Galvanized
JDX-1420	14	2000	2.4	
JDX-1610	16	1000	1.6	
JDX-1620	16	2000	3.2	
JDX-1630	16	3000	4.7	
JDT-1410	14	1000	1.2	Copper plated
JDT-1420	14	2000	2.4	
JDT-1610	16	1000	1.6	
JDT-1620	16	2000	3.2	
JDT-1630	16	3000	4.7	
JBT-1410	14	1000	1.25	Copper coated
JBT-1420	14	2000	2.5	
JBT-1610	16	1000	1.68	
JBT-1620	16	2000	3.36	
JBT-1630	16	3000	4.95	

The grounding rods are made in according to three coated ways. "JDX" type are made of hot-dip galvanized steel, "JDT" type are made of copper plated steel, "JBT" type are made of copper coated steel.

3. Insulator Pin

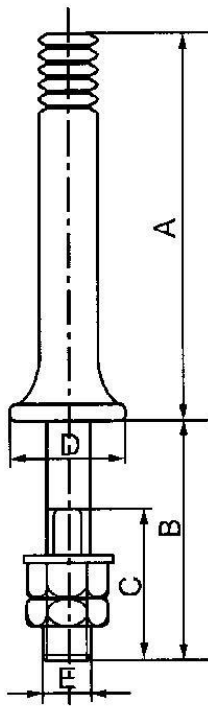

Catalog No.	Steel Head A(inch)	Dimensions (mm)					Weight (kg)	Remarks
		A	B	C	D	E		
GJB-20	Re15	115	140	75	32	18	0.8	For wood cossarms
GJB-22	Re15	165	140	75	38	18	0.99	
GJB-24	Re15	230	140	75	40	22	1.59	
GJB-26	Re16	165	140	75	44	18	1.28	
GJB-28	Re16	230	140	75	50	22	2.09	
GJB-30	Re16	305	140	75	63	22	2.84	For Steel crossarms
GJB-21	Re15	115	50	45	32	18	0.65	
GJB-23	Re15	165	50	45	38	18	0.89	
GJB-25	Re15	230	50	45	40	22	1.37	
GJB-27	Re16	165	50	45	44	18	1.10	
GJB-29	Re16	230	50	45	50	22	1.87	
GJB-31	Re16	305	50	45	63	22	2.62	

The body is made of hot-dip galvanized drop forged steel, lead pin-head meets BS standard.

4. Insulator Pin

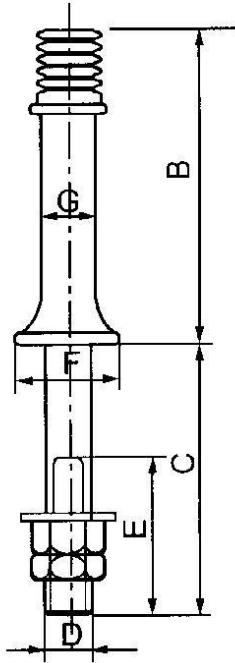

Catalog No.	Steel Head A (inch)	Dimensions (mm)						Weight (kg)	Remarks
		B	C	D	E	F	G		
GJA-3	1	127	140	16	76	50	20	1.20	For wood crossarms
GJA-5	1	152	146	16	76	50	20	1.28	
GJA-6	1	152	165	16	76	50	20	1.35	
GJA-7	1	152	165	20	82	50	22	1.50	
GJA-13	1-3/8	152	178	20	76	76	25	1.55	
GJA-14	1-3/8	203	178	20	76	76	25	1.70	
GJA-17	1-3/8	254	178	20	76	89	28	2.00	
GJA-18	1-3/8	305	178	20	76	89	28	2.30	For Steel corssarms
GJA-8	1	127	44	20	38	44	16	0.95	
GJA-9	1	127	44	12	38	50	20	1.00	
GJA-16	1	152	44	16	38	50	20	1.20	
GJA-11	1	152	44	16	38	50	21	1.30	
GJA-20	1-3/8	178	44	20	38	76	25	1.35	
GJA-21	1-3/8	203	44	20	38	76	25	1.45	
GJA-24	1-3/8	254	44	20	38	80	28	1.68	
GJA-25	1-3/8	303	44	20	38	80	28	1.90	

The body is made of hot-dip galvanized drop forged steel, lead pin-head meets ANSI standard.

5. Pole Top Pin

Catalog No.	Steel Head A (inch)	Dimensions (mm)					Weight (kg)
		B	F	H	D	E	
GJQ-1266	1	127	17.5	254	406	-	1.52
GJQ-1368	1	76	17.5	229	456	76	1.85
GJQ-740	1	127	21	279	508	76	2.70
GHQ-720	1-3/8	127	21	279	508	-	2.90

Made of hot-dip galvanized steel. Lead Thread Pin meets ANSI standard.

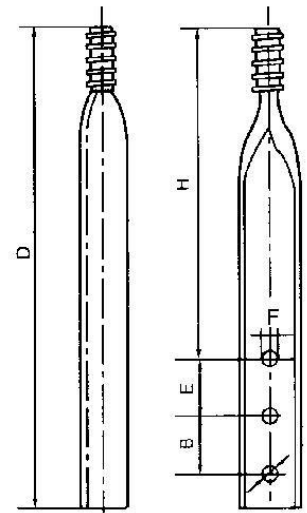

6. Ground Wire Support

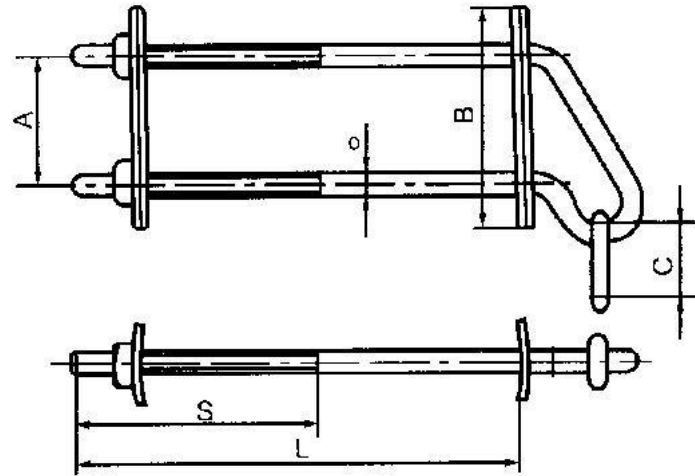

Catalog No.	Dimensions (mm)						Weight (kg)
	L	S	A	B	C	φ	
DZ-01	292	127	102	178	57	16	2.8
DZ-02	343	191	102	178	57	16	2.9

Made of hot-dip galvanized steel.

7. Guy Attachment

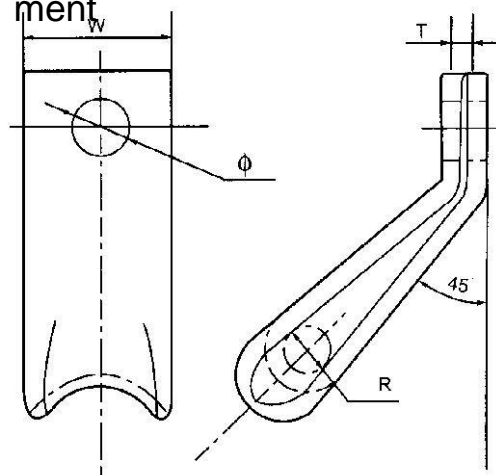

Catalog No.	Dimensions (mm)				Weight (kg)
	W	T	φ	R(Min.)	
LX-11	40	6	17.5	6	0.50
LX-22	50	6	21.0	8	0.50

Made of hot-dip galvanized steel.

8. Guy Attachment

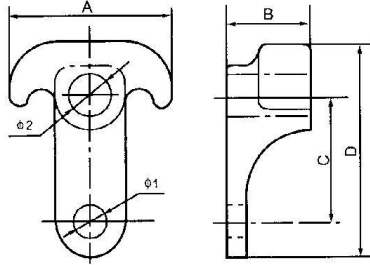

Catalog No.	Dimensions (mm)						Weight (kg)
	A	B	C	d	φ ₁	φ ₂	
LX-01	80	40	62	105	12.7	22	0.70
LX-02	84	34	62	105	14.3	22	0.74

Made of hot-dip galvanized malleable iron.

9. Stay Rod

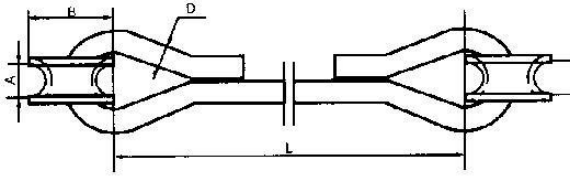

Catalog No.	Dimensions (mm)				Weight (kg)
	A	B	D	L	
LG-01	17.5	47	12	2800	3.80
LG-02	17.5	47	16	3200	6.70
LG-03	22.0	47	22	3800	13.60

Made of hot-dip galvanized steel.

10. Eye Bolt With Thimble

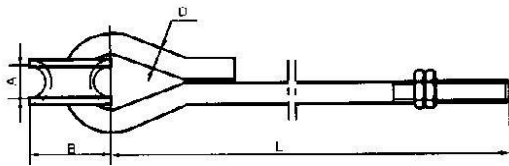

Catalog No.	Dimensions (mm)				Weight (kg)
	A	B	D	L	
LG-11	17.5	47	16	1828	3.90
LG-12	22.0	51	20	2438	6.72
LG-13	22.0	65	20	3048	11.50

Made of hot-dip galvanized steel.

11. Twin Eye Nut

Catalog No.	Dimensions (mm)						Weight (kg)
	A	B	C	D	E	F	
4005	32	25	17	16	32	35	0.70
4007	32	25	17	20	32	35	0.68

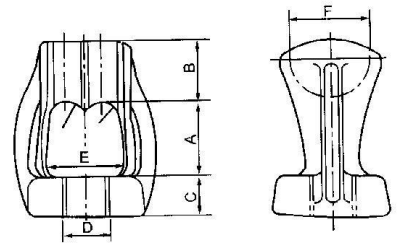

Made of hot-dip galvanized drop forged steel.

12. Oval Eye Nut

Catalog No.	Dimensions (mm)						Weight (kg)
	A	B	C	D	E	F	
4015	67	44	19	16	13	29	0.25
4017	76	44	19	20	13	38	0.28

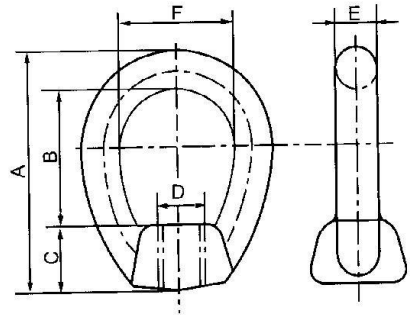

13. Angle Thimbleye

Made of hot-dip galvanized drop forged steel.

U.T.S is 62kN.

Weight is 0.6kg.

